

**Design No. P710**

May 01, 2003

**Restrained Assembly Rating — 1 Hr**

**Unrestrained Assembly Rating — 3/4 Hr**

**Unrestrained Beam Rating — 1 Hr**

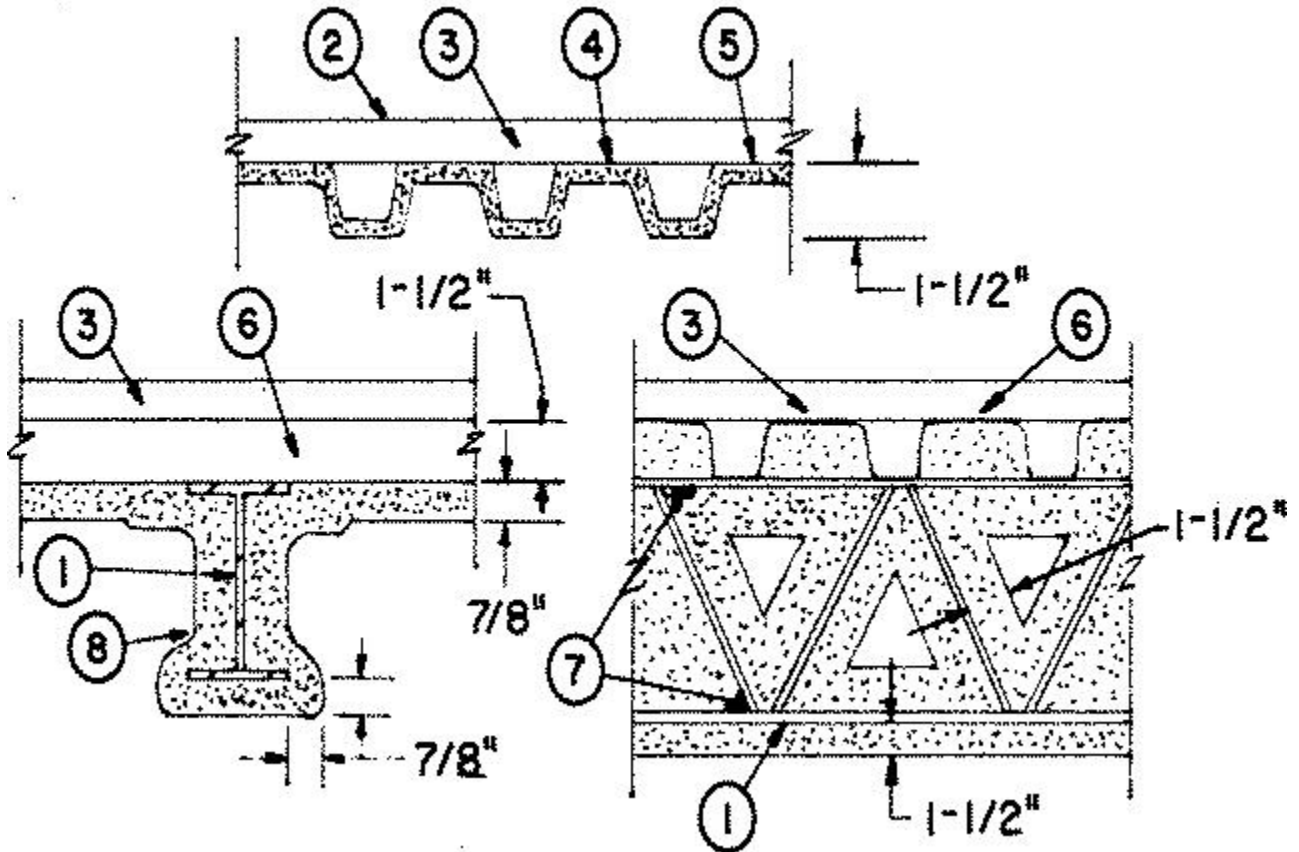

1. **Beam** — W6X16 min size, or **Steel Joist** — 14J7 with min web area of 0.31 in.<sup>2</sup>.

2. **Roof Covering\*** — Consisting of hot mopped or cold application materials compatible with insulation(s) described herein which provide Class A, B or C coverings. See Roofing Materials and Systems Directory-Roof Covering Materials(TEVT).

2A. In lieu of Item 2, roof covering consisting of single-ply Roofing Membrane\* that is either ballasted, adhered or mechanically attached as permitted under the respective manufacturer's Classification. See Fire Resistance Directory-Roofing Membranes (CHCI).

2B. Metal Roof Deck Panels\*-(Not Shown)-In addition to or in lieu of Items 2 or 2A, the roof covering may consist of a mechanically fastened metal roof deck panel assembly. See Fire Resistance Directory-Metal Roof Deck Panels (CETW).

3. **Roof Insulation** — May consist of the following:

A. **Mineral and Fiber Boards\*** — Applied in one or more layers to a minimum thickness or 1-1/2 in. May be loosely laid or applied with adhesive. When more than one layer is used, each layer of board to be offset in both directions. From layer below a min. of 6 in. in order to lap all joints.

**BMCA INSULATION PRODUCTS INC** — Permalite.

**FIBREX INSULATIONS INC** — FBX Baseboard and FBX Capboard.

**GAF MATERIALS CORP** — GAFTEMP Perlite.

**JOHNS MANVILLE INTERNATIONAL INC**

**ROXUL INC** — Toprock.

B. Or 5/8 in thick, 2.2 psf minimum weight **Gypsum Board** (Classified or Unclassified), supplied in 4 ft wide sheets. Installed perpendicular to the steel roof deck with joints staggered and occurring over the crests of the roof deck. Secured to the deck with Adhesive\* applied at a rate of 0.4 gal/100 sq ft. See Gypsum Board (BWFR or CKNX) and Adhesives (BYWR) categories for names of manufacturers.

a). And **Foamed Plastic\***, 1 to 8 in. thick, density of 2.5 pcf max, polystyrene foamed plastic insulation boards secured to the wallboard with asphalt glaze coat or adhesive.

(Note: Adhesive and/or asphalt glazer coat may be omitted when Item 1A is used). See Foamed Plastic (BRYX) category in the Building Material Directory or (CCVW) category in the Fire Resistance Directory for names of manufactures.

b). Or **Foamed Plastic\***, polyisocyanurate foamed plastic insulation boards, applied in one or more layers over the gypsum wallboard. Min thickness is 1.3 in. with no maximum for overall thickness. When applied in more than one layer, each layer to be offset in both directions from layer below a min of 6 in. in order to lap all joints. Adhesive\* (Item 4 or 4A) may be applied between layers of insulation and to vapor retarder (or gypsum wallboard if vapor retarder is not used).

**APACHE PRODUCTS CORPORATE** — Pyrox.

**ATLAS ROOFING CORP** — AC Foam II, AC Foam III.

**BPB AMERICA INC** — Types L, O.

**CARLISLE SYNTEC INCORPORATED** — Types HP, HP-H, HP-N, HP-W.

**FIRESTONE BUILDING PRODUCTS CO, DIV OF BFS DIVERSIFIED PRODUCTS L L C** — "ISO 95+FK", "ISO 95+GL", "ISO 95+GRF""ISO 95+GW", "ISO 300".

**GAF MATERIALS CORP** — Isotherm R.

**HUNTER PANELS** — H Shield.

**JOHNS MANVILLE INTERNATIONAL INC** — ENRGY 2, ENRGY 3, ISO-1, PSI 25.

**LOADMASTER SYSTEMS INC** — Loadmaster Polyisocyanurate Insulation.

**RMAX INC** — Multi-Max FA, Multi-Max FA-3.

**STEVENS ROOFING SYSTEMS, DIV OF JPS ELASTOMERICS CORP** — "Stevens ISO 2000", "Stevens ISO 3000".

**TREMCO INC** — Trisotech G.

c). Or **Building Units\*** — Min 1.3 in thick polyisocyanurate foamed plastic insulation boards (measured at thinnest section of polyisocyanurate), nom 48 by 48 or 96 in., faced on underside with mineral and fiber boards. Boards to be installed with end joints staggered a min of 6 in. in adjacent rows.

**ATLAS ROOFING CORP**

d). Or **Building Units\*** — Polyisocyanurate foamed plastic insulation boards faced on the underside with wood fiber board. Min thickness of the polyisocyanurate core is 1.3 in. No limit on max overall thickness. Boards to be installed with end joints staggered a min of 6 in. in adjacent rows.

**JOHNS MANVILLE INTERNATIONAL INC** — ENRGY 2 Plus.

e). Or **Building Units\*** — Polyisocyanurate foamed plastic insulation boards, nom 48 by 48 or 96 in., faced on the top surface with oriented strand board. Min thickness of the polyisocyanurate core is 1.3 in. No limit on max overall thickness. Boards to be installed with end joints staggered a min of 6 in. in adjacent rows.

**JOHNS MANVILLE INTERNATIONAL INC** — Type Nailboard.

**MARTIN FIREPROOFING GEORGIA INC** — Perform-A-Deck Nailable Roof Insulation.

f). Or **Building Units\*** — Polyisocyanurate foamed plastic insulation boards faced on the underside (or both sides) with mineral fiber board. Min thickness of the polyisocyanurate core is 1.3 in. No limit on max overall thickness. Boards to be installed with end joints staggered a min of 6 in. in adjacent rows.

**JOHNS MANVILLE INTERNATIONAL INC** — Fesco-Foam.

g). or **Building Units\*** — Not Shown — Composite polyisocyanurate foamed plastic insulation board with an adhered nailing surface, nom 48 by 48 or 96 in. may be used with the following limitations. These composite building units have ventilation slots internal to the panels. The building units are applied over gypsum wallboard. The thickness of the panel depends upon the thinnest portion of the polyisocyanurate insulation. The following dimensions apply to the polyisocyanurate insulation, min 1.3 in. thick. There is no limit on the max insulation thickness.

**GAF MATERIALS CORP** — Type INSUL-AIR.

**JOHNS MANVILLE INTERNATIONAL INC** — Type ISO-VENT.

h). or **Building Units\*** — Polyisocyanurate foamed plastic insulation boards, nom 48 by 48 or 96 in., faced on the top surface with gypsum board. Min thickness of the polyisocyanurate core is 1.3 in. No limit on overall thickness. Boards to be installed with end joints staggered a min of 6 in. in adjacent rows.

**JOHNS MANVILLE INTERNATIONAL INC** — ENRGY 2 Gypsum Composite.

4. **Adhesive\*** — (optional) — Used with insulation board. Applied at rate of 0.4 gal per 100 sq ft in 1/2 in. wide ribbons approx 6 in. OC.

See **Adhesives (BYWR)** category for names of manufacturers.

4A. **Adhesive\* -(Optional)** — (Bearing the UL Classification Marking for Roof Systems (TGFU)) - The vapor retarder, the gypsum wallboard or the first layer of roof insulation may be secured with adhesive to the steel crest surfaces. Also used to attach the vapor retarder to gypsum wallboard, the first layer of insulation to vapor retarder or gypsum wallboard and each additional layer of insulation. Applied at a max rate of 19.8 g/ft<sup>2</sup>.

**CARLISLE SYNTEC INCORPORATED** — FAST 100

5. **Vapor Retarder — Sheathing Material \*** — Optional — Applied with adhesive to roof deck units, overlapped approx 2 in. on sides.

See **Sheathing Materials (CHIZ)** category for names of manufacturers.

6. **Steel Roof Deck — (Unclassified)** — Min 1-1/2 in. deep, No. 22 MSG galv steel. Min width of 24 in., flutes spaced 6 in. OC. Attached to supports with 3/4 in. puddle welds approx 9 in. OC. Side joints crimped or button punched at 2 ft OC; or: Classified Steel Floor and Form Units\* — Noncomposite 1-1/2 in. deep, 36 in. wide, fluted galv steel deck. Min gauge is 22 MSG. Attached to supports with 3/4 in. puddle welds approx 9 in. OC.

Side joints crimped or button punched at 2 ft. OC.

**CONSOLIDATED SYSTEMS INC** — Types B, BI, F, N and NI. Units may be ptd/ptd.

7. **Bridging** — 1-1/4 by 1-1/4 by 1/8 in. cold-rolled steel angle bridging between joists. Protected with 1 in. of Spray-Applied Fire Resistive Materials.

8. **Spray-Applied Fire Resistive Materials\*** — Applied by mixing with water and spraying in more than one coat to final thicknesses indicated, to steel surfaces which must be free of dirt, oil, or scales. Min avg and min ind density of 15/14 pcf respectively. For method of density determination, refer to Design Information Section.

**ARABIAN VERMICULITE INDUSTRIES** — Type MK-5.

**GRACE CANADA INC** — Types MK-4, MK-5.

**GRACE KOREA INC** — Types MK-6/CBF, MK-6/ED, MK-6/HY, MH-65, Monokote Acoustic 1.

**W R GRACE & CO - CONN**

**CONSTRUCTION PRODUCTS DIV** — Types MK-4, MK-5, MK-6/HY, MK-6s, RG, Monokote Acoustic 1.

**PYROK INC** — Type LD.

**SOUTHWEST VERMICULITE CO** — Types 4, 5, 5EF, 5GP, 5MD, 8EF, 8GP, 8MD, 9EF, 9GP, 9MD.

**VERMICULITE PRODUCTS INC** — Types MK-4, MK-5, VP4, VP5.

9. **Metal lath** — (Optional, not shown) — Metal lath may be used to facilitate the spray application of spray-applied resistive materials on steel bar joists and trusses. The diamond mesh, 3/8 in. expanded steel lath, 1.7 to 3.4 lb/sq yd is secured to one side of each steel joist with No. 18 SWG galv steel wire at joist web and bottom chord members, spaced 15 in. O.C. max. When used, the metal lath is to be fully covered with spray-applied resistive materials with no min thickness requirements.

9A. **Nonmetallic fabric mesh** — (Optional, not shown) — As an alternate to metal lath, glass fiber fabric mesh, weighing approximately 2.5 oz/sq yd, polypropylene fabric mesh, weighing

approximately 1.25 oz/sq yd or equivalent, may be used to facilitate the spray application. The mesh is secured to one side of each joist web member. The method of attaching the mesh must be sufficient to hold the mesh and the spray-applied resistive materials in place during application until it has cured. An acceptable method to attach the mesh is by embedding the mesh in minimum 1/4 in. long beads of hot melted glue. The beads of glue shall be spaced a maximum of 12 in. O.C. along the top chord of the bar joist. Another method to secure the mesh is by 1-1/4 in. long by 1/2 in. wide hairpin clips formed from No. 18 SWG or heavier steel wire.

\*Bearing the UL Classification Mark

**Reprinted from the Online Certifications Directory with permission from Underwriters Laboratories Inc.**

**Copyright © 2005 Underwriters Laboratories Inc.®**