

Design No. P407

July 31, 2000

Restrained Assembly Rating — 2 Hr.

Unrestrained Assembly Rating — 2 Hr.

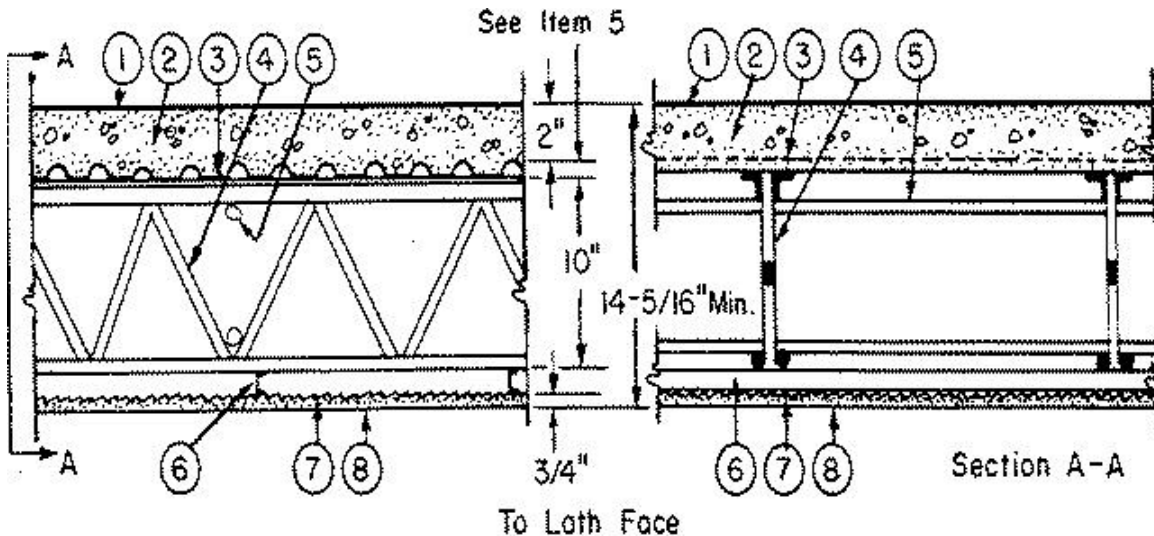

1. **Roof Covering*** — Consisting of hot mopped or cold application materials compatible with insulation(s) described herein which provide Class A, B or C coverings. See Roofing Materials and Systems Directory-Roof Covering Materials(TEVT).

1A. **In lieu of Item 1,** — roof covering consisting of single-ply **Roofing Membrane*** that is either ballasted, adhered or mechanically attached as permitted under the respective manufacturer's Classification. See Fire Resistance Directory — **Roofing Membranes (CHCI)**.

2. **Insulating Concrete** — Various types of insulating concrete prepared as specified below:

A. **Perlite Concrete** — 6.2 cu ft Perlite Aggregate* to 94 lbs. of Portland cement and 1-1/2 pt air entraining agent. Compressive strength 80 psi min.

See Perlite Aggregate (CFFX) category for names of Classified companies.

B. **Cellular Concrete — Roof Topping Mixture*** — Foam concentrate mixed with water and Portland cement per manufacturer's specifications. Cast dry density and 28-day compressive strength of min 190 psi as determined in accordance with ASTM C495-66.

CELCORE INC — Cast dry density of 31 (+ or -) 3.0 pcf.

ELASTIZELL CORP OF AMERICA — Type II. Mix #1 of cast dry density 39 (+ or -) 3.0 pcf, Mix #2 of cast dry density 40 (+ or -) 3.0 pcf, Mix #3 of cast dry density 47 (+ or -) 3.0 pcf.

LITE-CRETE INC — Cast dry density of 29 (+ or -) 3.0 pcf.

CELLULAR CONCRETE L L C — Cast dry density 37 (+ or -) 3.0 pcf.

SIPLAST INC — Mix #2. Cast dry density of 36 (+ or -) 3.0 pcf.

C. **Cellular Concrete — Roof Topping Mixture*** — Foam Concentrate mixed with water, Portland Cement and UL Classified Vermiculite Aggregate per manufacturer's application instructions. Cast dry

density of 33 (+ or -) 3.0 pcf and 28-day compressive strength of min 250 psi as determined in accordance with ASTM C495-86.

CELLULAR CONCRETE L L C — Mix #3.

SIPLAST INC — Mix #3.

3. **Steel Roof Deck** — (Unclassified) — Min 9/16 in. deep and 25-3/4 in. wide, galv, corrugated steel deck. Min gauge is 28 MSG. Continuous over three or more spans. Welded with 14 MSG welding washers 12 in. OC to each joist. Adjacent sheets overlapped one corrugation or,

Classified Steel Floor and Form Units* — Noncomposite 9/16, 7/8, 15/16, 1-5/16, or 1-1/2 in. deep, 27 to 36 in. wide, galv units. Min gauge is 28 MSG for corrugated and 22 MSG for fluted units. Spacing of welds attaching units to supports shall not exceed 12 in. OC. Corrugated units welded to supports through welding washers. Adjacent corrugated units overlapped one corrugation. Adjacent fluted units button-punched or welded together 36 in. OC along side joints.

CONSOLIDATED SYSTEMS INC — Types EHD, HD, S, SD.

4. **Steel Joists** — Type 10J2 min size, spaced not over 4 ft O.C. and welded to end supports.

5. **Bridging** — 1/2 in. diam steel bars welded to top and bottom chords of each joist.

6. **Furring Channels** — No. 16 MSG cold-rolled steel 3/4 in. deep, spaced 13-1/2 in. O.C., wire-tied to each joist with 16 SWG galv tie wire. Ends of channels to clear walls by 1/2 in.

7. **Metal Lath** — Diamond mesh, 3.4 lbs per sq yd, expanded steel.

8. **Plaster** — Scratch and brown coats: 2 cu ft **perlite plaster aggregate*** to 100 lb of fibered gypsum. Total thickness — 3/4 in to face of lath.

AIRLITE PROCESSING CORP OF FLORIDA

HARBORLITE CORP

REDCO II

*Bearing the UL Classification Mark

Reprinted from the Online Certifications Directory with permission from Underwriters Laboratories Inc.

Copyright © 2005 Underwriters Laboratories Inc.®