

Design No. P231  
December 09, 2002

Restrained Assembly Rating — 1 and 1-1/2 Hr.

(See Items 5, 6 and 7)

Unrestrained Assembly Rating — 1 and 1-1/2 Hr.

(See Items 5, 6 and 7)

Unrestrained Beam Ratings — 1 and 1-1/2 Hr.

(See Items 1, 5, 6 and 7)

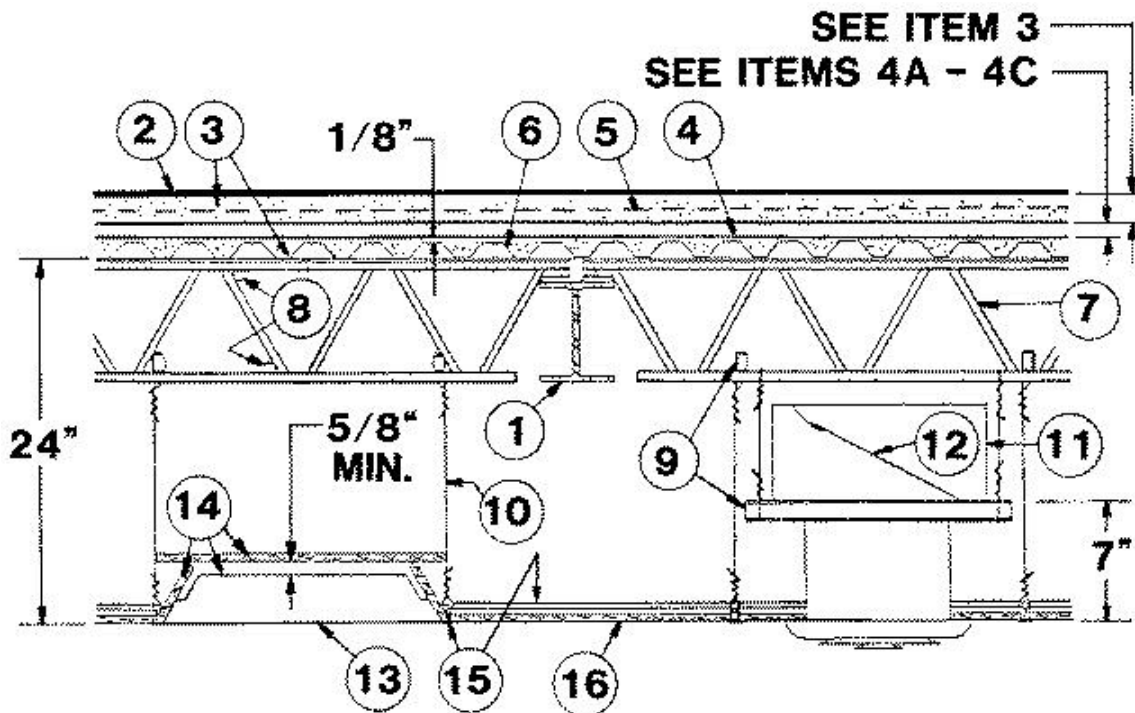

1. **Beam** — W8 x 15, min size for 1 Hr Unrestrained Beam Rating, W8 x 24, min size for 1-1/2 Hr Unrestrained Beam Rating. As an alternate, Steel Joist Girder of 20 in. min depth, 14 lbs per lin ft min weight, with min steel area of 1.12 sq in. for chord members. Min distance between bottom of joist girder and bottom of the ceiling is 14 in. For lowering the ceiling, the suggested method of using intermediate supports described under Suspension Systems in the Design Information Section General should be followed.

2. **Roof Covering\*** — Consisting of hot mopped or cold application materials compatible with insulation(s) described herein which provide Class A, B or C coverings. See Roofing Materials and Systems Directory-Roof Covering Materials (TEVT).

2A. **In lieu of Item 2, roof covering consisting of single-ply Roofing Membrane\*** — that is either ballasted, adhered or mechanically attached as permitted under the respective manufacturer's Classification. See Fire Resistance Directory-Roofing Membranes (CHCI).

3. **Insulating Concrete** — Perlite concrete, vermiculite concrete or cellular concrete roof topping mixture. The min thickness of the insulating concrete above the foamed plastic shall be 2-1/4 in. The max thickness shall be determined by job site conditions. The concrete shall be mixed as specified below:

A. **Perlite Concrete** — 6 cu ft of **perlite aggregate\*** to 94 lb of Portland cement and 1-1/2 pints of air entraining agent.

See Perlite Aggregate (CFFX) category for names of manufacturers.

B. **Vermiculite Concrete** — 6 cu ft of **vermiculite aggregate\*** to 94 lb of Portland cement and 0.5 lb of air entraining agent.

**SIPLAST INC**

**VERMICULITE PRODUCTS INC**

C. **Cellular Concrete — Roof Topping Mixture\*** — Foam concentrate mixed with water and Portland cement per manufacturer's specifications. Cast dry density and 28-day compressive strength of min 190 psi as determined in accordance with ASTM C495-66.

**CELCORE INC** — Cast dry density of 31 (+ or -) 3.0 pcf.

**CELLUFOAM CONCRETE SYSTEMS, DIV OF CELLUFOAM CONCRETE OF**  
— Cast dry density of 30 (+ or - 3.0) pcf.

**ELASTIZELL CORP OF AMERICA** — Type II. Mix #1 of cast dry density 39 (+ or -) 3.0 pcf, Mix #2 of cast dry density 40 (+ or -) 3.0 pcf, Mix #3 of cast dry density 47 (+ or -) 3.0 pcf.

**ENGLEHARD CORP**

**EXHAUST CONTROLS INC** — Cast dry density 37 (+ or -) 3.0 pcf.

**LITE-CRETE INC** — Cast dry density of 29 (+ or -) 3.0 pcf.

**SIPLAST INC** — Mix #2. Cast dry density of 36 (+ or -) 3.0 pcf.

D. **Cellular Concrete — Roof Topping Mixture\*** — Foam Concentrate mixed with water, Portland Cement and UL Classified Vermiculite Aggregate per manufacturer's application instructions. Cast dry density of 33 (+ or -) 3.0 pcf and 28-day compressive strength of min 250 psi as determined in accordance with ASTM C495-86.

**CELLULAR CONCRETE L L C** — Mix #3.

**ENGLEHARD CORP**

**EXHAUST CONTROLS INC** — Mix #3.

**SIPLAST INC** — Mix #3.

4A. **Foamed Plastic\*** — (Optional) — Foamed plastic insulation boards with holes and/or slots. Nom size 24 by 48 by 1 in. thick. For **1 Hr Restrained and Unrestrained Assembly Ratings**, max thickness is 8 in. For use only with perlite concrete.

**CELLOFOAM NORTH AMERICA INC**

**APACHE PRODUCTS CO**

4B. **Foamed Plastic\*** — (Optional) — Foamed plastic insulation boards with holes and/or slots. Nom size 24 by 48 by 1 in. thick. For **1 Hr Restrained and Unrestrained Assembly Ratings**, max thickness is 8 in. For use only with vermiculite concrete.

## SIPLAST INC

### VERMICULITE PRODUCTS INC

4C. **Foamed Plastic\*** — (Optional) — Nom 24 by 48 in., 48 by 48 in. or 30 by 60 in. by 1 in. thick polystyrene foamed plastic insulation boards with holes symmetrically placed having a max density of 2.0 pcf. For 1 Hr Restrained and Unrestrained Assembly Ratings, max thickness is 8 in. For use only with cellular concrete roof topping mixture.

### STARRFOAM MFG INC

4D. **Foamed Plastic\*** — (Optional) — Foamed plastic insulation boards with holes and/or slots. Nom size 24 by 48 by 1 in. thick. **For 1 HR Restrained and Unrestrained Assembly Ratings**, max thickness is 8 in. For use only with cellular concrete roof topping mixture.

See Foamed Plastic\* (BRYX) category in Building Materials Directory or Foamed Plastic\* (CCVW) category in Fire Resistance Directory for list of manufacturers. Any polystyrene foamed plastic insulation boards meeting the above specifications and bearing the UL Classification Marking with a flame spread value of 10 or less and a smoke developed value of 130 or less may be used.

5. **Wire Mesh** — No. 19 SWG galv steel twisted to form 2 in. hexagons. In addition, straight 16 SWG galv steel woven into mesh and spaced 3 in. apart for stiffness. Mesh installed without attachment perpendicular to supports and overlapped 6 in. at the sides. As an alternate, 4 x 8-12/14 SWG or 2 x 2-14/14 SWG welded wire fabric may be used. The wire mesh may be omitted provided that the steel roof deck (Item 6) is loaded not more than 75 percent of its bending capacity.

5A. **Fiber Reinforcement\*** — (Optional) - For use only with Roof-Topping Mixtures\* manufactured by Cellular Concrete LLC. In lieu of Wire Mesh (Item 5), Fiber Reinforcement may be added to roof topping mixtures (Items 3C or 3D), provided that the steel roof deck (Item 6) is loaded not more than 75 percent of its bending capacity. See Fiber Reinforcement (CBXQ) Category for rate that fibers are added to roof topping mixture.

**FORTA CORP** — Types Econo-Mono, Mighty-Mono, Stucco-Bond, Econo-Net, Cast-Master , Super-Net, Ultra-Net.

6. **Steel Roof Deck** — (unclassified) — Noncomposite design, 1-5/16 to 15/16 in. deep galv units. Corrugated steel form units, nom 34 in. wide, 24 or 26 MSG min thickness. Welded to supports not over 15 in. OC. Adjacent units overlapped one corrugation. Or

**Classified Steel Floor and Form Units\*** — Noncomposite design, 15/16, 1-5/16 or 1-1/2 in. deep, nom 24 to 36 in. wide, galv corrugated or fluted steel deck. Min gauge for corrugated deck is 26 MSG, min for fluted deck is 22 MSG. Welded to supports 15 in. OC max. Adjacent corrugated units overlapped one corrugation along each side. Fluted units button-punched or welded together 36 in. OC along sides. The loading of the roof deck shall not produce more than 75 percent of its allowable bending stress when the wire mesh (Item 5) is not used for the 1 hr ratings.

**CONSOLIDATED SYSTEMS INC** — Consoliform and Comvent Types EHD, HD, SD.

7. **Steel Joists** — Type 10J4 or 12K1, min size, spaced 48 in. O.C. and welded to end supports. Type 10H4, min size, spaced 48 in. O.C. and welded to end supports may be used for the 1 HR. Restrained and Unrestrained Assembly Ratings. Joist spacing may be increased to 72 in. O.C. where double cold-rolled channels (Item 9A) are used for attachment of hanger wires.

8. **Bridging** — Steel bars, 1/2 in. diam welded to top and bottom chords of each joist.

9. **Cold Rolled Channels** — No. 16 MSG cold-rolled steel channels, 1-1/2 in. deep with 9/16 in. flanges. Placed on bottom chord of joists and secured with 18 SWG galv steel wire. Installed

perpendicular to joists, located as required to provide hanger wire attachment points. When steel joists are spaced more than 4 ft O.C., two cold-rolled channels placed back to back, and tied together at 24 in. O.C. and to the bottom chord of the joists with No. 12 SWG galv steel wire, are required to provide attachment provision for ceiling hanger wires.

**10. Hanger Wire** — No. 12 SWG galv steel wire, twist-tied to bottom chord of joists or cold-rolled channels. Located 48 in. O.C. along main runners, at all four corners of light fixtures, at midpoint of cross tees adjacent to light fixtures and duct outlets, and adjacent to main runner splices.

**11. Air Duct** — No. 24 MSG min galv steel. Total area of duct openings not to exceed 255 sq in. per each 100 sq ft of ceiling area. Area of duct opening not to exceed 255 sq in. Max dimension of opening 18 in. Inside and outside faces of duct throat protected with 1/16 in. thick ceramic fiber paper laminated to the metal. Supported by 1-1/2 in. deep, 16 MSG cold-rolled steel channels spaced not over 48 in. OC suspended by 12 SWG galv steel wire.

**12. Damper** — No. 16 MSG min galv steel, sized to overlap duct opening 2 in. min. Protected on both sides with 1/16 in. thick ceramic fiber paper laminated to the metal and held open with a **Fusible Link** (Bearing the UL Listing Mark).

**13. Fixtures, Recessed Light** — (Bearing the UL Listing Mark). Fluorescent lamp type, steel housing, 2 by 4 ft size. Fixtures spaced so their area does not exceed 24 sq ft per 100 sq ft ceiling area. Wired in conformance with the National Electrical Code. Fixtures and ballasts must be considered for these ambient temperature conditions before installation.

**13A. Fixture Stabilizer** — (Not shown) — For use with the Type 1650 metal pans (See Item 15A); one min 0.047 in. thick (16 MSG) galv steel channel yoke per light fixture, secured to the web at midspan of cross tee on each side of fixture.

**13B. Fixture Stabilizer** — (Not shown) (Optional) — Min 0.020 in. thick (25 MSG) painted steel spacer bar formed as an angle with 1 in. legs and hemmed edges and slots perpendicular to and near the ends of the spacer bar for engaging over the bulb of the tees. Engaged over the bulb at midspan of the cross tees on each side of all light fixtures and over the bulb of the adjacent cross tee.

**14. Fixture Protection — Acoustical Material\*** — 5/8 in. thick, cut to form a five sided enclosure, trapezoidal in cross-section, approx 1/2 in. longer and wider and 5/8 in. higher than the light fixture housing. The fixture protection consists of a 23-3/4 by 47-3/4 in. top piece, two 5-7/8 by 47-3/4 in. side pieces, and two 4-1/2 by 23-3/4 in. end pieces. The top edge of each fixture protection side piece may be provided with a 1 in. deep by 10 in. long notch near its midpoint. The side and top pieces are laid in place and the end pieces are held in place with three 8d nails spaced 8 in. OC. (S)=Surface perforations.

**ARMSTRONG WORLD INDUSTRIES INC** — Type 5/8 in. P (S).

**15. Steel Framing Members\*** — Main runners nom 12 ft long, spaced 4 ft OC. Cross tees nom 4 ft long, installed perpendicular to main runners and spaced 2 ft OC. When the ceiling is composed of nom 24 by 24 in. lay-in panels, cross tees nom 2 ft long installed perpendicular to 4 ft cross tees and spaced 4 ft OC.

**ARMSTRONG WORLD INDUSTRIES INC** — Types AFG, AFG-A . Type GLBP (consisting of main runners, 4 ft cross tees and steel straps) for use with 24 by 48 in. Type P lay-in panels.

**BPB AMERICA INC** — Types PAC, PCH, PCS

**CHICAGO METALLIC CORP** — Types 250, 260, 1250, 1260, 1850, 1860.

15A. **Steel Framing Members\*** — Main runners 10 or 12 ft long, spaced 4 ft OC. Cross tees nom 4 ft long, installed perpendicular to main runners and spaced 2 ft OC. When nom 2 by 2 ft lay-in panels are used, nom 2 ft long cross tees installed perpendicular to 4 ft cross tees at midspan, spaced 4 ft OC. Border panels supported at walls by min. 0.016 in. thick painted steel angle with 7/8 in. legs or min. 0.016 in. thick painted steel channel with a 1 by 1-9/16 by 1/2 in. profile.

**CGC INTERIORS, DIV OF CGC INC** — Types DXL, DXLZ, SDXL.

**USG INTERIORS INC** — Types DXL, DXLZ, SDXL.

15B. **Steel Framing Members\*** — **Metal pans** — (Not shown) (Optional) — Channel-shaped metal pans in various colors and finishes, installed perpendicular to cross tees or main runners and spaced 4 or 6 in. OC. The flange edges of the metal pans engage and interlock with the vertical tabs of the corresponding grid adapters with tabs 4 or 6 in. OC. (See Item 15B). End laps joints of the metal pans shall occur adjacent to main runners or cross tees. The metal pans shall each be supported by at least two main runners or cross tees.

**CHICAGO METALLIC CORP** — Type 1650.

15C. **Steel Framing Members\*** — **Grid adapter** — (Not shown) (Optional) — For use with Type 1650 metal pans (See Item 15A). Angle shaped adapter with a looped return flange; installed parallel to cross tees or main runners by engaging return flange of adapter to the flange of the cross tee or main runner. The 48 or 24 in. long adapters are intended for use with cross tees or main runners, respectively.

**CHICAGO METALLIC CORP** — Type 1650.

15D. **Steel Framing Members\*** — **Filler strips** — (Not shown) (Optional) — For use with Type 1650 metal pans. Filler strips are 0.018 to 0.024 in. thick, steel or aluminum, 13/32 or 5/8 in. deep by 3/4 in. wide, placed between the metal pans.

**CHICAGO METALLIC CORP** — Type 1650.

16. **Acoustical Material\*** — Nom 24 by 24 or 48 in. lay-in panels. Border panels supported at walls by min 0.016 in. thick (26 gauge) painted steel angle with 7/8 in. legs; or min 0.016 in. thick (26 gauge) painted steel channel, 1-1/2 in. deep with 7/8 in. flanges. (S)=Surface perforations.

**ARMSTRONG WORLD INDUSTRIES INC** — Type 5/8 in. P (S).

17. **Hold-Down Clips** — (Not shown) — 0.020 in. thick (No. 20 gauge) spring steel, placed over cross tees 2 ft OC.

\*Bearing the UL Classification Mark

**Reprinted from the Online Certifications Directory with permission from Underwriters Laboratories Inc.**

**Copyright © 2005 Underwriters Laboratories Inc.®**