

Design No. D216
November 26, 2002

Restrained Assembly Ratings — 1, 1-1/2, 2 and 3 Hr.

(See Items 2, 3, 7, 11, 12, 20, 20E, 20F, 20G and 21)

Unrestrained Assembly Ratings — 1, 1-1/2, 2 and 3 Hr.

(See Items 2, 3, 7, 11, 12, 20, 20E, 20F, 20G and 21)

Unrestrained Beam Ratings — 1, 1-1/2, 2 and 3 Hr.

(See Items 11, 12, 20, 20E, 20F, 20G and 21)

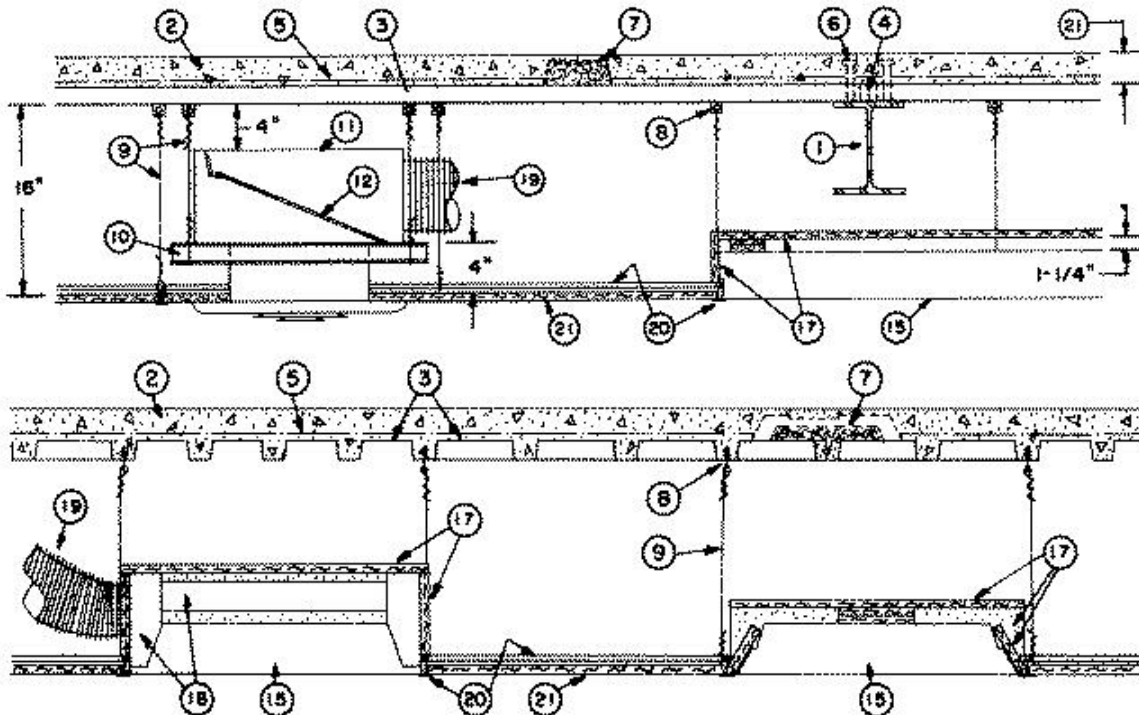

1. **Beam** — W8x15, min size. As an alternate to steel beams, standard steel joists, Type 10J3, 12K1 or LH Series joists of any size may be used as an alternate to steel beams. Joist girders, 20 in. min depth and 13 lb/lin ft min weight may also be used as alternate to steel beams.

As an alternate to steel beams or standard joists, custom made steel joists designed as composite or noncomposite with the concrete slab, per S. J. I. specifications, for a max tensile stress of 30 KSI. Min depth of custom made joists shall be 10 in. with min area of steel for top and bottom chord members of 0.96 and 0.77 sq in. respectively. Min area of steel for end diagonal web member shall be 0.444 sq in. Min area of steel of the first six interior web members shall be 0.406 sq in. min area of steel for all other interior web members shall be 0.196 sq in. Custom made joists designed noncomposite with concrete slab. Steel filler pieces of proper size, 1 to 2 in. long shall be welded to and between the top chord angles midway between all top chord panel points. Spacing of joists not limited. Lateral bracing required per Steel Joist Institute specifications. A min clearance of 8 in. shall be maintained between bottom chord of joists and face of ceiling.

2. **Normal Weight or Light Weight Concrete** — Carbonate or siliceous aggregate, 150 (+ or -) 3 pcf unit weight, 3000 psi compressive strength, vibrated. Lightweight concrete, expanded shale or slate aggregate by rotary kiln method or expanded clay aggregate by rotary kiln or sintered grate method; 110 (+ or -) 3 pcf

unit weight, 3000 psi compressive strength, 4 to 7 percent entrained air, liberated. See Item No. 21 for concrete topping thickness required for hourly ratings.

3. **Steel Floor And Form Units*** — Composite, 1-1/2, 2 or 3 in. deep, min 22 MSG galv fluted units and/or composite 1-1/2, 2 or 3 in. deep, min 20/20 MSG galv cellular units. When a blend of fluted and cellular units is used, the concrete topping thickness shall be measured from the top plane of the cellular units. Welded to supports 12 in. OC. Adjacent units button-punched or welded together 36 in. OC at side joints. See Item No. 21 for hourly ratings with various combinations of steel floor units.

CONSOLIDATED SYSTEMS INC — 24 or 36 in. wide Types CFD-2, CFD-3; 24, 30 or 36 in. wide Type CFD-1.5. Units may be phos/ptd.

Alternate Construction — Noncomposite units of the same type listed above may be used provided allowable loading is calculated on the basis of noncomposite design.

4. **Joint Cover** — 2 in. wide pressure-sensitive cloth tape. Where fluted and cellular floor units are installed end to end, galv steel angles shall be tack-welded to the cellular floor units in such a manner as to cover the cells.

5. **Welded Wire Fabric** — 6x6-W1.4xW1.4.

6. **Shear Connectors** — (Optional) — Studs, 3/4 in. diam with 1-1/4 in. diam by 1/2 in. thick head or equivalent per AISC specifications. 1/2 in. concrete cover required above top of shear connector.

7. **Electrical Inserts** — Preset electrical inserts Classified as "**Outlet Boxes and Fittings Classified for Fire Resistance.**" * Unless specified otherwise for a particular preset electrical insert type, the spacing of the preset electrical inserts shall be not less than 24 in. OC along cellular steel floor units with not more than one preset electrical insert in each 4 sq ft of floor area.

H H ROBERTSON — Inserts.

(Tapmate II-FN, II-EAFN; Series KEB)

Installed per accompanying installation instructions over factory-punched holes in QL-AKX or QL-WKX floor units. Inserts are used in the pre-active, active, or abandoned condition. The holes cut in the insert cover for passage of wires shall be no more than 1/8 in. larger diam than the wire. For abandonment of Tapmate inserts, see installation instructions. Abandonment requires use of KEB-PC insert cover with no holes in it (for all Tapmate inserts), or a KEB-PC2 or -PC2-A1 abandonment cover for Tapmate II-EAFN only.

The Tapmate II-FN insert may use KEB-HP-1 outlet box fittings in lieu of the KEB-PC flush cover fittings.

For 2 h Restrained and Unrestrained Assembly Ratings only, installed per accompanying installation instructions over factory punched holes in 24 in. wide QL-GKX floor units alternating with 36 in. wide, 3 in. deep QL-99 fluted units. Inserts are used in the pre-active, active or abandoned condition. The holes cut in insert cover for passage of wires shall be no more than 1/8 in. larger diameter than the wire. For abandonment of Tapmate inserts, see installation instructions.

H H ROBERTSON — Tapmate II-FN, II-EAFN; Series KEB; Tapmate IV-FN-S, IV-FN-H, IV-EAFN; Series KED.

(2) **Walker Systems Inc.** Inserts.

(N-R-G Bloc IV Preset Inserts; FAKM-II, RAKM-II, S36BB, S36BC, S36CC Service Fittings)

Installed per accompanying installation instructions over factory-punched holes in 3 in. deep K-Type cellular steel floor units. Either Type RAKM-II, FAKM-II, S36BB, S36BC or S36CC service fittings are installed with Type N-R-G Bloc IV Series preset inserts per accompanying installation instructions. Refer to installation instructions for Classified assemblies.

(PK Series Preset Insert; FAKM-II, RAKM-II, S36BB, S36BC, S36CC Service Fittings)

For 2 h Restrained and Unrestrained Assembly Ratings only, installed per accompanying installation instructions over factory punched holes in 24 in. wide WDR2 or WDR3 floor units. Either Type FAKM-II, RAKM-II, S36BB, S36BC or S36CC service fittings are installed with Type PK Series preset inserts per accompanying installation instructions. Refer to installation instructions for Classified assemblies.

WALKER SYSTEMS INC — Type N-R-G Bloc IV Series inserts; Type RAKM-II, FAKM-II, S36BB, S36BC or S36CC service fittings. Type PK Series inserts; Type RAKM-II, FAKM-II, S36BB, S36BC or S36CC service fittings.

8. **Hanger Clips** — Min 0.045 in. thick (18 gauge) galv steel, 2 in. wide, 3-1/2 in. long, hooked at one end for attachment over male leg of steel floor units, spaced as required for hanger wire attachment.

8A. **Hanger Clips** — (Not shown). For use with 2 and 3 in. QL-99, -AKX, -WKX floor units. Min 0.045 in. thick (18 gauge) galv steel, 1-5/8 in. overall width (horizontal leg) and 3-3/4 in. long (vertical leg). The horizontal leg ends with a hook and a lip. The hook is 3/32 in. wide and inclined 8 deg to the vertical to fit over the vertical leg at the side joint of the units.

9. **Hanger Wire** — No. 12 SWG galv steel, pigtailed in concrete through steel floor units, prior to concrete placement, or attached to hanger clips (Items No. 8 or 8A). Hanger wires spaced 48 in. O.C. or at every other main runner/cross tee intersection, whichever dimension is smaller, along main runners. One hanger wire to occur at all four corners of light fixtures, at midspan of cross tees adjacent to 4 and 5 ft long light fixtures and air duct outlets, at midspan of each 5 ft long cross tee, at midspan of each cross tee when nom 48 by 48 in. lay-in panels are used, and adjacent to each main runner splice. Additional hanger wires required at the midspan of cross tees running parallel and nearest to the walls and near the end of cut cross tees longer than 2 ft. which abut walls.

10. **Cold Rolled Channels** — Min 0.053 in. thick (16 gauge) cold-rolled steel channels, 1-1/2 in. deep, placed under air duct and supported by hanger wires at each end, spaced not over 48 in. O.C. and on each side of duct outlet to support air duct.

11. **Air Duct** — No. 24 MSG min galv steel. Total area of duct openings not to exceed 144 sq in. per each 100 sq ft of ceiling area with the total area of each individual duct opening not to exceed 144 sq in. Where permitted as described in Item No. 21, the total area of duct openings may be increased to 576 sq in. per each 100 sq ft of ceiling area with the area of each individual duct opening not to exceed 576 sq in. Max dimension of 144 sq in. opening is 12 in. Max dimension of 576 sq in. opening is 30 in. Where air duct penetrates through a suspension system member, each cut end of the suspension system member near the duct outlet must be independently supported by a hanger wire.

12. **Damper** — No. 22 MSG galv steel, sized to overlap duct opening 2 in. min. Protected on both surfaces with 1/16 in. thick ceramic fiber paper and held open with a **Fusible Link** (bearing the UL Listing Mark).

Where permitted as described in Item No. 21, Duct Outlet Protection System A as described in the Design Information Section may be used in lieu of the damper described above.

13. **Air Terminal Units*** — Linear Air Diffusers — (Optional — Not Shown) — 4 ft long units. Located in openings formed by two cross tees spaced 2 in. O.C. on each side of a 20 by 48 in. light fixture when ceiling is composed of nom 24 by 48 in. lay-in panels. Linear air diffuser to be located on one side of fixture with a linear air return (Item No. 14) to be located on opposite side of fixture to complete the 2 by 4 ft grid module. Linear air diffusers attached to web of each cross tee with steel sheet metal screw at midpoint. Each linear air diffuser supported by 12 SWG hanger wire at its quarter-points. A max of 12 lin ft of linear air diffuser is allowed per each 100 sq ft of ceiling area.

14. **Air Terminal Units*** — **Linear Air Returns** — (Optional — Not Shown) — 4 ft long units. Located in openings formed by two cross tees spaced 2 in. O.C. on each side of a 20 by 48 in. light fixture when ceiling is composed of nom 24 by 48 in. lay-in panels. Linear air return to be located on one side of fixture with a linear air diffuser (Item No. 13) to be located on opposite side of fixture to complete the 2 by 4 grid module. Linear air returns attached to web of each cross tee with steel sheet metal screw at midpoint. Each

linear air return supported by 12 SWG hanger wire at its midpoint. A max of 12 lin ft of linear air return is allowed per each 100 sq ft of ceiling area.

15. Fixtures, Recessed Light — (Bearing the UL Listing Mark). Fluorescent lamp type, steel housing, 1 by 4 ft, 2 by 2 ft, 2 by 4 ft, 20 by 48 in., and 20 by 60 in. size. The nom 1 by 4 ft, 2 by 2 ft, and 2 by 4 ft fixtures may be provided with or without vented sides for air boots (Item No. 18). Air boots must be used in conjunction with fixtures designed for that purpose. The nom 1 by 4 ft, 2 by 2 ft, and 2 by 4 ft fixtures may be provided with or without vented tops for air return purposes. Linear air diffusers (Item No. 13) and linear air returns (Item No. 14) must be used in conjunction with nom 20 by 48 in. fixtures. When nom 20 by 60 in. fixtures are used, fixture stabilizers (Item No. 16) shall be used in addition to the hanger wires occurring at the midspan of the 5 ft long cross tees. When nom 1 by 4 ft fixtures are used, aggregate of fixtures not to exceed four per 100 sq ft of ceiling area. When nom 2 by 2 ft fixtures are used, aggregate of fixtures not to exceed five per 100 sq ft of ceiling area. When nom 2 by 4 ft, 20 by 48 in., or 20 by 60 in. fixtures are used, aggregate of fixtures not to exceed three per 100 sq ft of ceiling area. Wired in conformance with the National Electrical Code. Fixtures and ballasts must be considered for these ambient temperature conditions before installation.

15A. Fixture, Recessed Light — (Bearing the UL Listing Mark) — (Not Shown) — As an alternate to Item 15 for 1 or 2 hr assembly ratings only. Incandescent or fluorescent lamp type, steel housing, nom 6-1/2 in. diam by 7-1/2 in. high. A max of two "high hat" fixtures may be substituted for each nom 2 by 4 ft size fluorescent light fixture permitted in the ceiling (max six "high hat" fixtures per 100 sq ft of ceiling area). Each fixture provided with a nom 6-1/2 in. by 10 in. painted steel base screw-attached to the fixture with four steel screws. Short sides of the base provided with adjustable steel hanger bars for fixture support. Two lengths of cold-rolled steel channel (Item 10) are to be suspended above and parallel with the fixture hanger bars to provide hanger wire attachment points for the fixture hanger bars and to support the light fixture protection panel (Item 17A). Wired in conformance with the National Electrical Code.

16. Fixture Stabilizer — (Not shown) — Required for 48 in. and 60 in. long light fixture sizes when metal pans (Item 20C) are used and only for 20 by 60 in. size fixtures when metal pans are not used. One 16 MSG painted steel channel formed as a yoke, secured to the web at midspan of cross tee on each side of fixture.

17. Fixture Protection — Acoustical Material* — 5/8 in. thick, cut into pieces to form a five sided enclosure, rectangular or trapezoidal in cross section dependent upon fixture type, approx 1/2 in. longer and wider than the fixture with sufficient depth to provide at least 1-1/4 in. clearance between the fixture and the enclosure. The pieces are held together by 8d nails. The 1-1/4 in. clearance shall be provided by spacers placed on top of fixture but located away from the ballasts. When non-air-handling or air return fixtures are used, a max 1-1/4 in. separation may be maintained between the long fixture protection side pieces and the top piece. When air supply light fixtures with air boots are used, fixtures and air boots shall be fully enclosed except for the nom 28 — q in. opening needed to accommodate connection to air supply duct. (S)=Surface perforations.

ARMSTRONG WORLD INDUSTRIES INC — Type P(S).

Alternate Fixture Protection — Batts and Blankets* — 1-1/4 in. thick, cut into pieces to form five sided enclosures as described above. Pieces held together by 18 SWG galv steel tie wire.

THERMAFIBER L L C — Type FR.

17A. Fixture Protection — Acoustical Material* — For use with "high hat" light fixtures (Item 15A). Nom 24 by 24 by 5/8 or 3/4 in. piece of the same acoustical material used in the ceiling (Item 21). Panel located max 1 in. above and centered over "high hat" light fixture with ends resting on cold-rolled steel channels.

18. Air Boots — No. 24 MSG galv steel air boots with internal glass fiber insulation are installed in pairs, along both sides of air supply light fixtures, and are connected by a 24 MSG galv steel crossover duct.

19. Air Duct Connector — 6 in. diam. Any Class O or Class I Air Duct Connector bearing the UL Listing Mark.

20. Steel Framing Members* — The steel framing members are provided with either steel or aluminum caps on the exposed flange, depending upon the steel framing member type. When aluminum capped members are used, the **Assembly and Beam Ratings** are 2 hr. Main runners and cross tees in combinations listed below:

A. Main runners nom 12 ft long, spaced 48 in. OC. Cross tees nom 4 ft long installed perpendicular to main runners and spaced 24 in. OC. When nom 1 by 4 ft light fixtures are used, additional 4 ft long cross tees installed along length center line of 2 by 4 ft grid modules; a field-cut nom 12 by 48 in. lay-in panel, bearing a min of 3/8 in. on suspension members, fills in the remainder of such modules. When nom 20 by 48 in. light fixtures and air terminal units (Item Nos. 13 and 14) are used, additional 4 ft long cross tees are installed parallel with and 2 in. from the 4 ft cross tees in the 2 by 4 ft grid module where 20 by 48 in. light fixture is to be installed. The ends of the 4 ft long cross tees forming the sides of the 20 by 48 in. grid module shall engage field-punched routes in the web of each main runner. The field-punched routes must be identical to factory-punched routes and shall be effected using a tool designed for that purpose and provided by the steel framing member manufacturer. When the ceiling is composed of nom 24 by 24 in. lay-in panels, cross tees nom 2 ft long installed perpendicular to 4 ft cross tees, midway between main runners, spaced 48 in. OC — For 24 by 24 or 48 in. lay-in panels.

ARMSTRONG WORLD INDUSTRIES INC — Types AFG, AFG-A, AFG-MX . When Type AFG-A steel framing members are used, the Assembly and Beam Ratings are 2 hr. When Type AFG-MX steel framing members are used with 24 by 48 in. panels, the assembly and beam ratings are 1-1/2 hr. When Type AFG-MX steel framing members are used with 24 by 24 in. panels, the assembly and beam ratings are 2 hr . Type GLBP (consisting of main runners, 4 ft cross tees and steel straps) for use with 24 by 48 in. Type P or PC lay-in panels. Type AFG-LT for use with 24 by 24 in. panels for max 2 hr beam and assembly ratings.

BPB AMERICA INC — Types PAC, PCH, PCS. When Type PAC steel framing members are used. the Assembly and Beam Ratings are 2 hr. When Type PCH steel framing members are used, the main runner ends may be riveted to the wall molding along one wall and the cross tee ends may be riveted to the wall molding along one adjacent wall. The rivets are intended to facilitate the ceiling installation, not to replace hanger wires .

BAILEY METAL PRODUCTS LTD — Type BEF .

CHICAGO METALLIC CORP — Types 250, 260, 1250, 1260, 1850, 1860. When the Type 260, 1260 or 1860 steel framing members are used, the Assembly and Beam Ratings are 2 hr. When Type 250, 260, 1850 or 1860 steel framing members are used, the main runner ends may be riveted to the wall molding along one wall and the cross tee ends may be riveted to the wall molding along one adjacent wall. The rivets area intended to facilitate the ceiling installation, not to replace hanger wires.

B. Main runners nom 12 ft long, spaced 60 in. OC. Cross tees nom 5 ft long installed perpendicular to main runners and spaced 24, 30 or 36 in. OC. Nom 2 ft long cross tees are used to support one end of a 2 by 4 ft light fixture in a 24 by 60 in. module; a field-cut nom 12 by 24 in. lay-in panel, bearing a min of 3/8 in. on suspension members, fills in the remainder of such modules. When nom 1 by 4 ft light fixtures are used, additional 5 ft long cross tees are installed to form 1 by 5 ft grid modules. Nom 1 ft long cross tees are used to support one or both ends of the 1 by 4 ft light fixture; field-cut lay-in panels, bearing a min of 3/8 in. on suspension members, fill in the remainder of such modules.— For 24, 30 or 36 by 60 in. lay-in panels.

CHICAGO METALLIC CORP — Types 250, 1250, 1850.

C. Main runners nom 12 ft long, spaced 48 in. OC. Cross tees nom 4 ft long installed perpendicular to main runners and spaced 48 in. OC — For 48 by 48 in. lay-in panels.

ARMSTRONG WORLD INDUSTRIES INC — Types AFG, AFG-A .

BPB AMERICA INC — Type PCH

CHICAGO METALLIC CORP — Types 250, 1250, 1850.

D. Main runners nom 12 ft long, spaced 36 in. OC. Cross tees nom 3 ft long installed perpendicular to main runners and spaced 24 or 36 in. OC. As an alternate for the 24 by 36 in. lay-in panels, main runners may be spaced 2 ft OC with nominal 2 ft long cross tees installed perpendicular to main runners and spaced 3 ft OC. — For 36 by 24 or 36 in. lay-in panels.

ARMSTRONG WORLD INDUSTRIES INC — Types AFG, AFG-A .

CHICAGO METALLIC CORP — Types 250, 260, 1250, 1260, 1850 or 1860. When the Type 260, 1260 or 1860 steel framing members are used, the Assembly and Beam Ratings are 2 hr.

E. Main runners nom 10 ft long, spaced 60 in. OC. Cross tees nom 5 ft long installed perpendicular to main runners and spaced 20 in. OC. Nom 20 in. long cross tees are used to support one or both ends of a 20 by 48 in. light fixture in a 20 by 60 in. module; a field-cut nom 12 by 20 in. or two field-cut nom 6 by 20 in. lay-in panels, bearing a min of 3/8 in. on suspension members, fill in the remainder of such modules — For nom 20 by 60 in. lay-in panels.

CHICAGO METALLIC CORP — Types 250, 260, 1250, 1260, 1850, 1860. When the Type 260, 1260 or 1860 steel framing members are used, the Assembly and Beam Ratings are 2 hr.

F. **Main runners** — Nom 10 or 12 ft long, spaced 4 ft OC. Cross tees - nom 4 ft long, installed perpendicular to main runner, spaced 2 ft OC. Border panels supported at walls by min. 0.016 in thick painted steel angle with 7/8 in legs or min. 0.016 in thick painted steel channel with a 1 by 1-9/16 by 1/2 in profile. When nom 1 by 4 ft light fixtures are used, additional 4 ft long cross tees installed along length center line of 2 by 4 ft grid modules; a field-cut nom 12 by 48 in lay-in panel, bearing a min of 3/8 in on suspension members, fills in the remainder of such modules. When nom 20 by 48 in light fixtures and air terminal units (Item Nos. 13 and 14) are used, additional 4 ft long cross tees are installed parallel, 2 in from each of the 4 ft cross tees in the 2 by 4 ft grid module where 20 by 48 in light fixture is to be installed. The ends of the 4 ft long cross tees forming the sides of the 20 by 48 in grid module shall engage field-punched routes in the web of each main runner. The field-punched routes must be identical to factory-punched routes and shall be effected using a tool designed for that purpose and provided by the steel framing member manufacturer. When the ceiling is composed of nom 24 by 24 in lay-in panels, cross tees nom 2 ft long installed perpendicular to 4 ft cross tees, midway between main runners, spaced 48 in OC. - For 24 by 24 or 48 in lay-in panels.

CGC INTERIORS, DIV OF CGC INC — Types DXL, DXLA, DXLZ, DXLZA, SDXL, SDXLA, ZXLA. When Types DXLA, DXLZA, SDXLA or ZXLA are used, the assembly and beam ratings are 2 hr

G. **Main runners** — Nom 10 or 12 ft long, spaced 5 ft OC. Cross tees - nom 5 ft long, installed perpendicular to main runners, spaced 2, 2-1/2 or 3 ft OC. Border panels supported at walls by min. 0.016 in thick painted steel angle with 7/8 in legs or min. 0.016 in thick painted steel channel with a 1 by 1-9/16 by 1/2 in profile. Nom 2 ft long cross tees are used to support one of a 2 by 4 ft light fixture in a 24 by 60 in module; a field-cut nom 12 by 24 in lay-in panel, bearing a min of 3/8 in on suspension members, fills in the remainder of such modules. When nom 1 by 4 ft light fixtures are used, additional 5 ft long cross tees are installed to form 1 by 5 ft grid modules. Nom 1 ft long cross tees are used to support one or both ends of the 1 by 4 ft light fixture; field-cut lay-in panels, bearing a min of 3/8 in on suspension members, fill in the remainder of such modules.- For 24, 30 or 36 by 60 in lay-in panels.

CGC INTERIORS, DIV OF CGC INC — Types DXL, DXLZ, SDXL, ZXLA. When Type ZXLA is used, the assembly and beam ratings are 2 hr.

H. **Main runners** — Nom 10 or 12 ft long, spaced 4 ft OC. Cross tees - nom 4 ft long installed perpendicular to main runners, spaced 4 ft OC. Border panels supported at walls by min. 0.016 in thick painted steel angle with 7/8 in legs or min. 0.016 in thick painted steel channel with a 1 by 1-9/16 by 1/2 in profile. For 4 by 4 ft lay-in panels.

CGC INTERIORS, DIV OF CGC INC — Types DXL, DXLA, DXLZ, DXLZA, SDXL, SDXLA, ZXLA. When Type DXLA, DXLZA, SDXLA or ZXLA are used, the assembly and beam ratings are 2 hr.

20A. **Steel Framing Members*** — For use with metric size panels described under Item 21. Main runners nom 3000 or 3600 mm long spaced 1200 mm OC., Cross tees nom 1200 mm long, installed perpendicular

to main runners, spaced 600 mm OC. When nom 600 by 600mm lay-in panels are used, nom 600mm long cross tees installed perpendicular to 1200mm cross tees at midspan, spaced 1200mm OC. For 600 by 600 or 1200 mm lay-in panels.

CGC INTERIORS, DIV OF CGC INC — Types DXL, DXLA, DXLZ, DXLZA, SDXL, SDXLA, ZXLA. When Types DXLA, DXLZA, SDXLA, ZXLA are used, the Assembly and Beam Ratings are 2 hr.

USG INTERIORS INC — Types DXL, DXLA, DXLZ, DXLZA, SDXL, SDXLA, ZXLA. When Types DXLA, DXLZA, SDXLA or ZXLA are used, the Assembly and Beam Ratings are 2 hr.

20B. Steel Framing Members* — Metal pans — (Not shown) (Optional) — Channel-shaped metal pans in various colors and finishes, installed perpendicular to cross tees or main runners and spaced 4 or 6 in. OC. The flange edges of the metal pans engage and interlock with the vertical tabs of the corresponding grid adapters with tabs 4 or 6 in. OC. (See Item 20C). End laps joints of the metal pans shall occur adjacent to main runners or cross tees. The metal pans shall each be supported by at least two main runners or cross tees.

CHICAGO METALLIC CORP — Type 1650.

20C. Steel Framing Members* — Grid adapter — (Not shown) (Optional) — For use with Type 1650 metal pans (See Item 20B). Angle shaped adapter with a looped return flange; installed parallel to cross tees or main runners by engaging return flange of adapter to the flange of the cross tee or main runner. The 48 or 24 in. long adapters are intended for use with cross tees or main runners, respectively.

CHICAGO METALLIC CORP — Type 1650.

20D. Steel Framing Members* — Filler strips — (Not shown) (Optional) — For use with Type 1650 metal pans. Filler strips are 0.018 to 0.024 in. thick, steel or aluminum, 13/32 or 5/8 in. deep by 3/4 in. wide, placed between the metal pans.

CHICAGO METALLIC CORP — Type 1650.

20E. Steel Framing Members* — 9/16 in. wide narrow flange grid may be used as an alternate to 15/16 in. wide flange grid systems. Main runners, nom 12 ft long spaced 4 ft OC. Cross tees, nom 4 ft long, installed perpendicular to main runners and spaced 2 ft OC. Cross tees, nom 2 ft long, installed perpendicular to 4 ft cross tees and spaced 4 ft OC. Type FSLK or PFSLK for use with Type P, nom 24 by 24 in. square edge or tegular edge lay-in panels. Type FSL for use with Type P, nom 24 by 24 in. tegular edge lay-in panels. Grid modules containing light fixtures must employ a fixture centering clip at each corner. The 24 gauge electrogalvanized steel clip is nested on the flange of the intersecting grid tees, has two 1-7/16 in. high legs with their sides perpendicular to each other and a U-shaped return at the top of each leg for engaging over the bulb of the intersecting grid tees.

ARMSTRONG WORLD INDUSTRIES INC — Type FSL, FSLK, PFSLK. Type FSLK and Type PFSLK cross tees may be used interchangeably with either Type FSLK or PFSLK main runners. When Type FSL steel framing members are used, the assembly and beam ratings are 1 hr. When Type FSLK or PFSLK steel framing members are used the assembly and beam ratings are 2 hr.

20F. Steel Framing Members* — 9/16 in. wide narrow flange grid may be used as an alternate to 15/16 in. wide flange grid systems. Main runners, nom 12 ft long, spaced 4 ft OC. Cross tees, nom 4 ft long, installed perpendicular to main runners and spaced 2 ft OC. Cross tees, nom 2 ft long, installed perpendicular to 4 ft cross tees and spaced 4 ft OC. For use with Type P, nom 24 by 24 in. square edge lay-in panels.

BPB AMERICA INC — Type PE, for 1 hr assembly and beam rating only .

CHICAGO METALLIC CORP — Type 4050, for 1 hr assembly and beam ratings only.

20G. Steel Framing Members* — Main Runners, nom 10 or 12 ft long spaced 4 ft OC. Cross tees, nom 4 ft long, installed perpendicular to main runners and spaced 2 ft OC. When nom 2 by 2 ft lay-in panels are

used, nom 2 ft long, cross tees installed perpendicular to 4 ft cross tees at midspan, spaced 4 ft OC. Border panels supported at walls by - steel wall angle with 7/8 in legs or channel with a 1 by 1-9/16 by 1/2 in profile. Type P, nom 24 in. by 24 in. square edge lay-in panels for use with DXLT or DXLTZ and Tegular edge for use with DXLF. When Type DXLT or DXLTZ steel framing members are used, the assembly and beam ratings are 1-1/2 hr. When Type DXLF steel framing members are used the assembly and beam ratings are 1 hr.

CGC INTERIORS, DIV OF CGC INC — Types DXLT, DXLF, DXLTZ.

USG INTERIORS INC — Types DXLT, DXLF, DXLTZ.

21. **Acoustical Material*** — Nominal 5/8 or 3/4 in. thick lay-in panels in nominal panel sizes and types tabulated below. Border panels supported at walls by 24 MSG painted steel channel, 1-1/2 in. deep, with a 15/16 in. bottom flange. (S)=Surface perforations, (P)=Through perforations. Footnotes on following page.

| Nom Panel Size In. | Acoustical Mtl Type | Concrete Topping Thkns In. | Steel Floor Unit Type | Restrained & Unrestrained Assembly Rating Hr | Unrestrained Beam Rating Hr |
|--------------------|-----------------------|----------------------------|-----------------------|--|-----------------------------|
| 20 by 60 | P(S or P) or PC(S)+++ | 2-1/2 | F, C or B | 2hr | 2 hr |
| 20 by 60 | P(S or P) or PC(S)++ | 2-1/2 | F or B ₁ | 2 hr | 3 hr |
| 20 by 60 | P(S)+ | 3-1/4 | F or B ₁ | 3 hr | 3 hr |
| 20 by 60 | P(S or P) or PC(S)++ | 3-1/2 | F or B ₁ | 3hr | 3 hr |
| 24 by 24 | BF(S)+++ | 2-1/2 | F, C or B | 2 hr | 2 hr |
| 24 by 24 | BF(S)++ | 2-1/2 | F | 2 hr | 3 hr |
| 24 by 24 | BF(S)++ | 3-1/2 | F | 3 hr | 3 hr |
| 24 by 24 or 36 | P(S)+++ | 2-1/2 | F, C or B | 2 hr | 2 hr |
| 24 by 24 or 36 | PC(S)+ | 2-1/2 | C or B | 2 hr | 2 hr |
| 24 by 24 or 36 | P(S)++ | 2-1/2 | F | 2 hr | 3 hr |
| 24 by 24 or 36 | P(S)++ | 3-1/2 | F | 3 hr | 3 hr |
| 24 by 48 or 60 | P(S or P) or PC(S)+++ | 2-1/2 | F, C or B | 2 hr | 2 hr |
| 24 by 48 or 60 | P(S or P) or PC(S)++ | 2-1/2 | F or B ₁ | 2 hr | 3 hr |
| 24 by 48 or 60 | P(S)+ | 3-1/4 | F or B ₁ | 3 hr | 3 hr |
| 24 by 48 or 60 | PC(S)+ | 3-1/4 | B ₁ | 3 hr | 3 hr |

| | | | | | |
|-------------------|------------------------|-------|---------------------|------|------|
| 20 by 48 or 60 | P(S or P) or PC(S)+ | 3-1/2 | F or B ₁ | 3 hr | 3 hr |
| 30 by 30 | P(S)+++ | 2-1/2 | F, C or B | 2 hr | 2 hr |
| 30 by 30 | PC(S)+ | 2-1/2 | C or B | 2 hr | 2 hr |
| 30 by 30 | P(S)++ | 2-1/2 | F | 2 hr | 3 hr |
| 30 by 30 | P(S)++ | 3-1/2 | F | 3 hr | 3 hr |
| 30 by 60 | P(S) or PC(S)++ | 2-1/2 | F, C or B | 2 hr | 3 hr |
| 30 by 60 | P(S)++ | 3-1/4 | F, C or B | 3 hr | 3 hr |
| 30 by 60 | PC(S)++ | 3-1/4 | C or B | 3 hr | 3 hr |
| 36 by 36 | PC(S)+++ | 2-1/2 | F, C or B | 2 hr | 2 hr |
| 36 by 36 | PC(S)++ | 2-1/2 | F or B ₁ | 2 hr | 3 hr |
| 36 by 36 | PC(S)+ | 3-1/4 | B ₁ | 3 hr | 3 hr |
| 36 by 36 | PC(S)++ | 3-1/2 | F or B ₁ | 3 hr | 3 hr |
| 36 by 60 | PC(S)++ | 2-1/2 | F, C or B | 2 hr | 3 hr |
| 36 by 60 | PC(S)++ | 3-1/4 | C or B | 3 hr | 3 hr |
| 36 by 60 | PC(S)++ | 3-1/2 | F | 3 hr | 3 hr |
| 48 by 48 | PC(S)++ | 2-1/2 | F, C or B | 2 hr | 3 hr |
| 48 by 48 | PC(S)++ | 3-1/4 | C or B | 3 hr | 3 hr |
| 48 by 48 | PC(S)++ | 3-1/2 | F | 3 hr | 3 hr |

F=All fluted steel floor units; C=All cellular steel floor units; B=Any blend of fluted and cellular floor units; B₁=Blend of one cellular steel floor unit to one or more fluted steel floor units.

+ — Hourly ratings apply when used in conjunction with Duct Outlet Protection System A.

++ — Hourly ratings apply when used in conjunction with either the larger duct outlets (576 sq in. per 100 sq ft of ceiling area) or Duct Outlet Protection System A, but not both.

+++ — Hourly ratings apply when used in conjunction with both the larger duct outlets (576 sq in. per 100 sq ft of ceiling area) and Duct Outlet Protection System A.

ARMSTRONG WORLD INDUSTRIES INC — Type 5/8 or 3/4 in. P, Type 5/8 in. PC, Type 3/4 in. BF. Type P (S, P) or PC(S) 15 mm thick 600X600 or 1200 mm. These metric size panels may only be used with the metric size grid described under item 20A. Hourly ratings shown for 24X24 in. size panels apply to 600X600 mm size panels while ratings shown for 24X48 in. panels apply to 600X1200 mm size panels.

21A. **Acoustical Materials* - Antenna Panel** — (Optional, Not Shown) - When the ceiling is composed of nom 24 by 24 in. lay-in panels, a lay-in acoustical ceiling panel with integral high frequency antennae may be included in the ceiling. Thickness, type and edge detail of antenna panel to match surrounding acoustical ceiling panels. Antenna panel to be installed in accordance with accompanying instructions. A max of one antenna panel may be used per each 100 sq ft of ceiling area.

ARMSTRONG WORLD INDUSTRIES INC

22. Speaker Assemblies For Fire Resistance* — (Optional Not Shown) — The speaker assemblies consist of speakers, speaker enclosures and their accessories. The ceiling penetration from the speaker enclosure shall not exceed 11-7/8 by 11-7/8 in. for the square speaker enclosures and 12 in. in diam for the round speaker enclosures. The speaker assemblies are installed in accordance with the installation instructions provided. A max of two 144 sq in. speaker assemblies per 100 sq ft of ceiling area is allowed.

ATLAS/SOUNDOLIER, DIV OF AMERICAN TRADING & PRODUCTION CORP

See **Speaker Assemblies For Fire Resistance (CHML)** , Atlas/Soundolier, Div of American Trading & Production Corp. for specific types.

22A. Speaker Assemblies For Fire Resistance* — (Optional, Not Shown) — As an alternate to Item 22, speaker panels may be included in the ceiling when the ceiling is composed of nom 24 by 24 or 48 in. lay-in panels. Nom 24 by 24 in. metal-framed lay-in speaker panels installed in accordance with the accompanying installation instructions. Hanger wires are required on the main runners and on the nom 4 ft long cross tees at all four corners of the speaker panel. Each speaker panel to be covered with a nom 24 by 24 in. panel of the same acoustical material used in the ceiling. Acoustical material panel to be centered over and supported by the metal "bridge" of the speaker panel. A max of one speaker panel is allowed per 100 sq ft of ceiling area with a min center-to-center spacing of 10 ft between speaker panels. — Model BP67XX ("XX" may be 00-99).

23. Hold Down Clips — (Not shown) — No. 28 MSG spring steel. When ceiling is composed of nom 24 by 24 in., 24 by 36 in., or 30 by 30 in. lay-in panels, one clip placed over bulb of cross tee near cross tee midpoint. When ceiling is composed of nom 20 by 60 in., 36 by 36 in., 24 by 48 in., 30 by 60 in., 36 by 60 in., or 48 by 48 in. lay-in panels, two clips placed over bulb of each cross tee near cross tee quarter-points. One leg of each clip is to be cut off when placed over bulb of cross tee adjacent to long side of light fixture.

24. Accessible Hold-Down Clips — (Not Shown) — No. 28 MSG spring steel. To be used in lieu of hold-down clips on each access panel in ceiling.

*Bearing the UL Classification Mark

Reprinted from the Online Certifications Directory with permission from Underwriters Laboratories Inc.

Copyright © 2005 Underwriters Laboratories Inc.®